

AS U260 surface mounted profile is applicable to all types of floors and load bearing capacity is designed for heavy vehicles or cars depending on the joint width. Chamfered side frames provide a smooth transition and striated surface ensures antislip. Especially recommended for the places where heavy duty profile with gasket is inquired. For flush mounted applications AS A261 is available.

- Application Areas** : Indoor & Outdoor / Floor
- Ideal for** : Factories, Warehouses, Car Parks, Airports etc.
- Material** : Mill Finish Aluminum (Anodizing optional), EPDM Gasket
- Aluminum Alloy** : 6063 AA-USA / EN AW 6063
- Optional Supplies** : Fire Barrier, Waterproof EPDM membrane

FLOOR

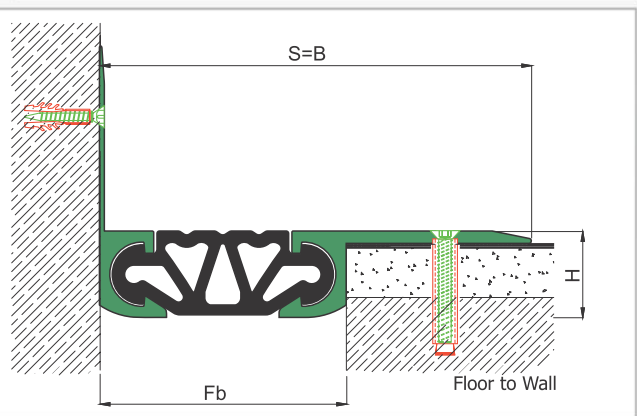
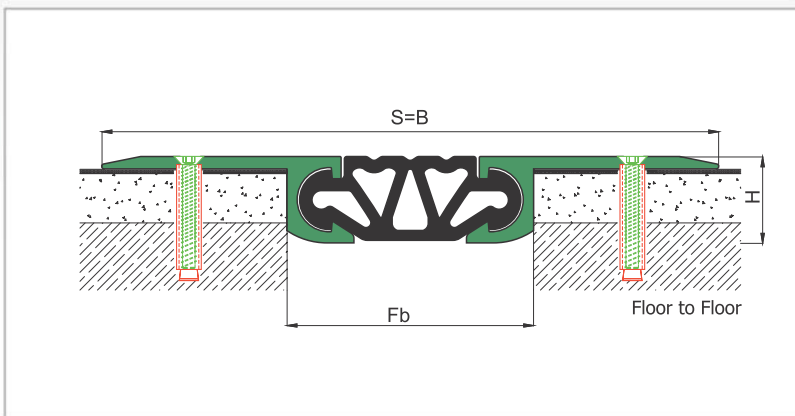
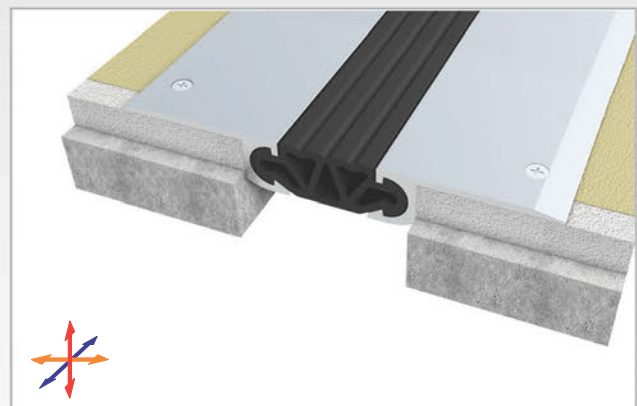
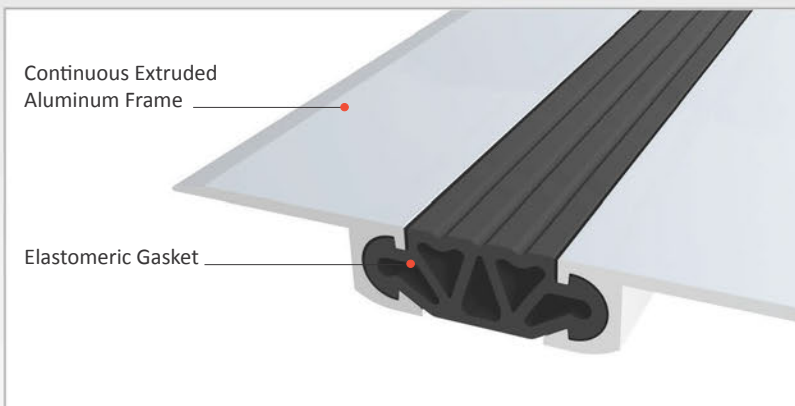

* Visuals are representative and the profile configuration may differ depending on the characteristics requested.

GASKET COLORS **BLACK**

LOCATION	MODEL	GAP (Fb) mm	HEIGHT (H) MM	OVERALL WIDTH (B) mm	VISIBLE WIDTH (S) mm	MOVEMENT (W) mm	LOAD CAPACITY	STANDARD LENGTH (mt)
Floor to Floor	AS U260-080	80	35	230	230	+4 / -8	35 kN 300 kN	3
	AS U260-100	100	35	250	250	+10 / -15	300 kN	3
	AS U260-150	150	40	330	330	+15 / -20		3

Note: Please ask for different sizes



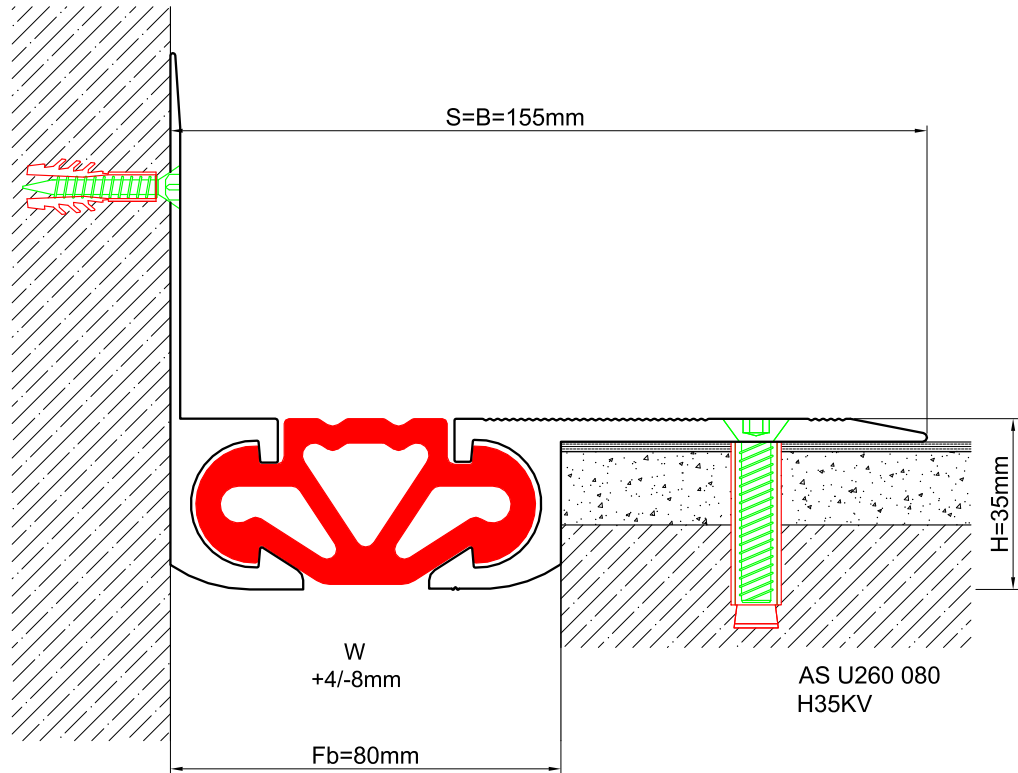
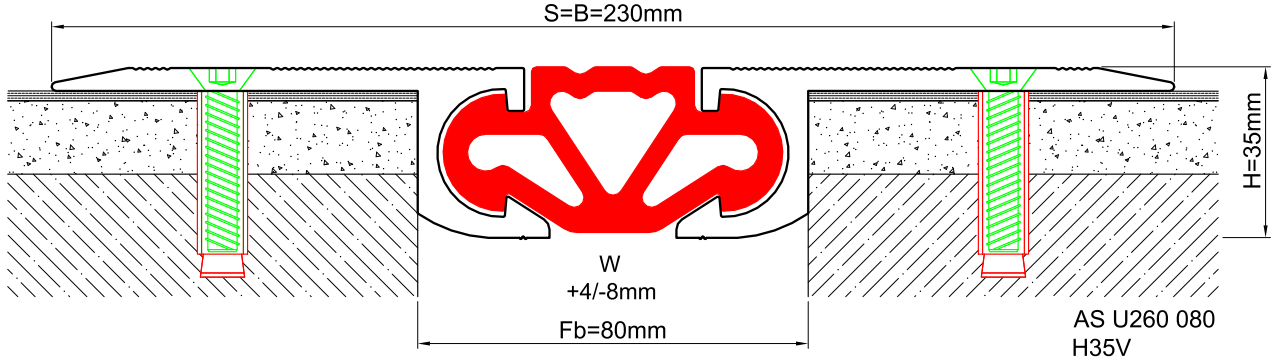

Profil No Profile Number	AS U260 080	AS U260 080K
Fb (mm)	80	80
H (mm) yaklaşık approx.	50	50
W± (mm) yaklaşık approx.	+4/-8	+4/-8
Renk Color	Alüminyum: Natürel, Fitiller: Siyah, gri, diğer Aluminum: Natural, Inserts: Black, grey, others	
Malzeme Material	Alüminyum, EPDM Kauçuk(siyah) Aluminum, EPDM Rubber(black)	
Standart Uzunluk Standard Length	3	
Yükleme Kapasitesi Load-Bearing Capacity	35kN 	300kN 